

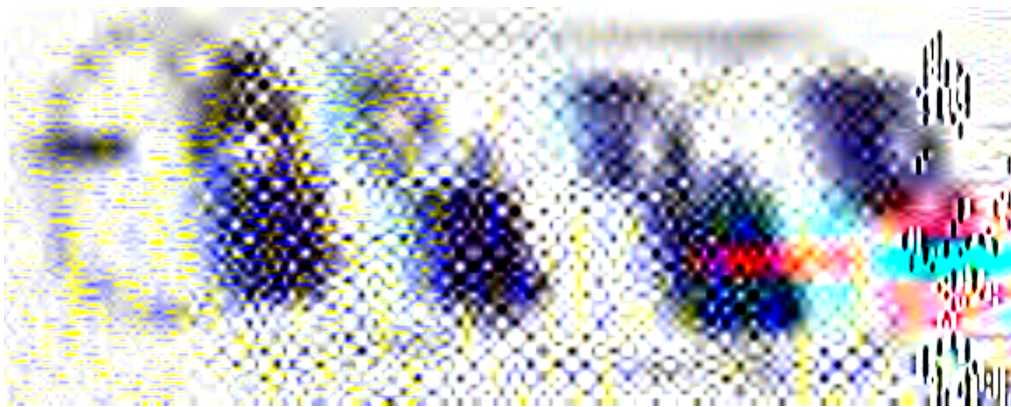





1.

	DN200-DN1500	
	°C 350°C	

	°C 350°C		°C 500°C	
			4	
	±	±	±	±
	±	±	±	±
	$P=1.29 * \rho * V^2$ ( Unit Pa) $\rho$ (kg/m <sup>3</sup> ) V (m/s) $\rho$ :density (kg/m <sup>3</sup> ) V:velocity(m/s)			
			1 4	

		°C	
		°C	
	12VDC~+24VDC	+24VDC 4-20mA	3.6V
	”	”	

1.

$$= \frac{0.101325+}{0.101325} \frac{273.15+ 20}{237.15+}$$

°C

°C

°C

1. 3. 1

$t=20^{\circ}\text{C}$ ,  $P_0=0.1\text{MPa}$ ,  $\rho=1.205\text{kg/m}^3$ )

$^{\circ}\text{C}$

1.3.1

 $(\text{m}^3/\text{h})$ 

(mm)			(mm)		
		Ex			Ex
15	0.2-5	0.1-5	15	4-16	3-20
20	0.35-10	0.2-10	20	5-30	4-40
25	0.55-12	0.3-12	25	8-80	5-90
32	0.9-18	0.5-18	32	10-150	6-200
40	1.5-25	0.9-25	40	14-280	9-310
50	2.5-40	1.5-40	50	20-400	14-490
65	3.5-70	2.5-70	65	35-720	24-840
80	5.5-130	3.5-130	80	55-1100	36-1440
100	8.5-160	5.5-160	100	80-1600	60-2440
125	15-250	8.5-250	125	130-2600	90-3600
150	20-400	12.5-400	150	190-3800	130-5200
200	34-700	22-700	200	330-6600	220-7700
250	53-1200	35-1200	250	530-10600	350-12400
300	76-1800	50-1800	300	760-15200	500-17800
350	104-3100	69-3100	350	1035-21000	690-24000
400	135-3500	90-3500	400	1350-27000	900-31000





$u$	
$v$	
$\rho$	
$\mu$	







1.9.1





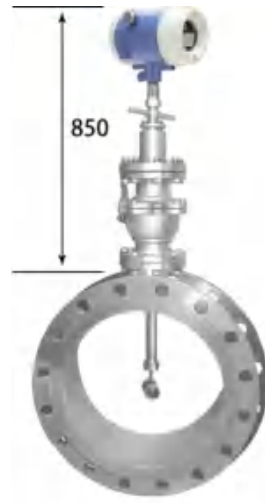
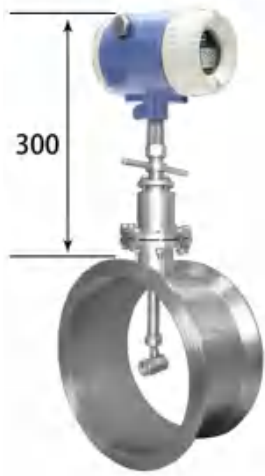



- 1
- 2
- 3
- 4
- 5



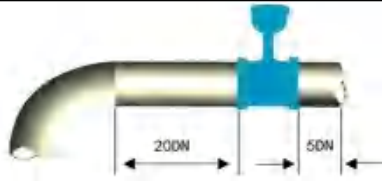
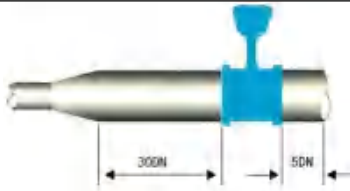
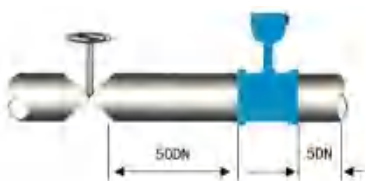
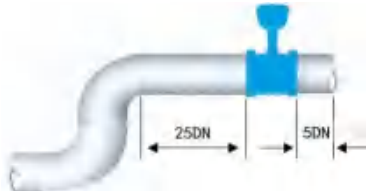

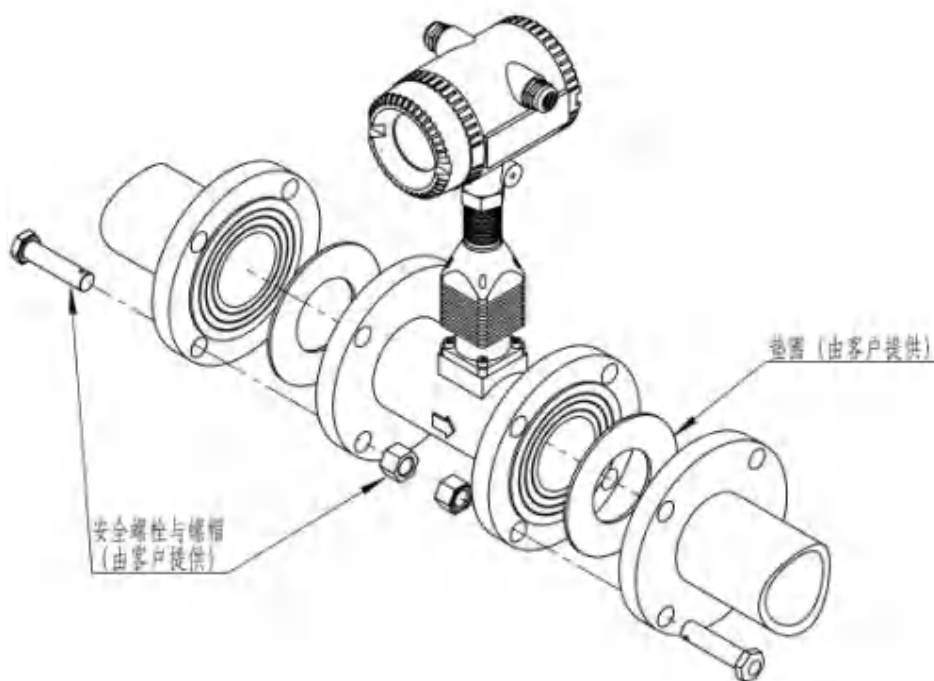

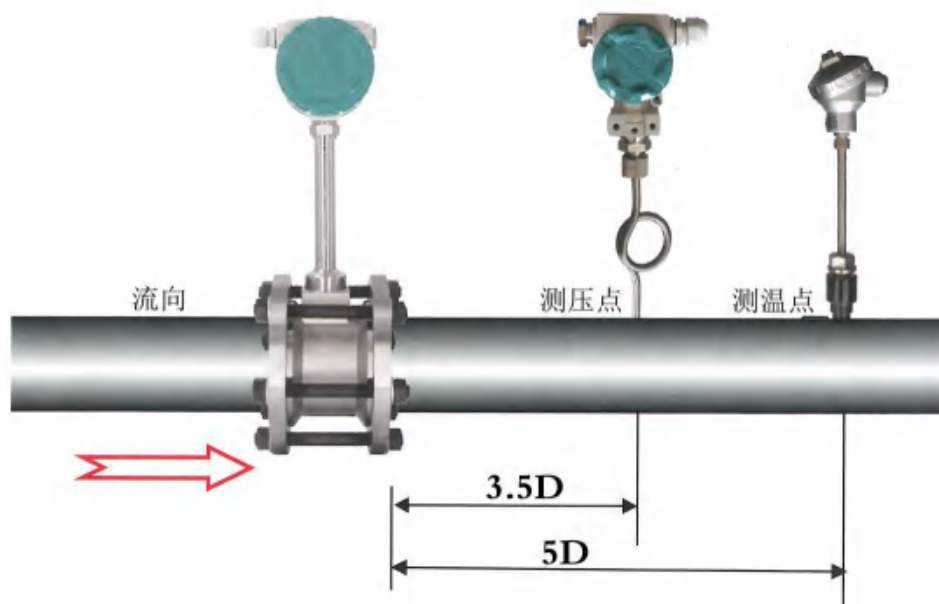
4.

)

(

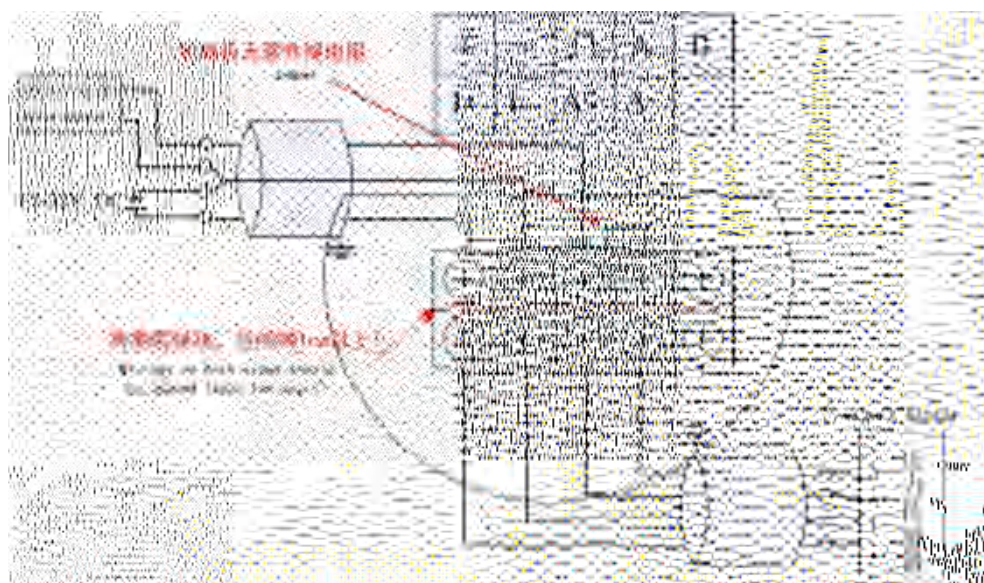
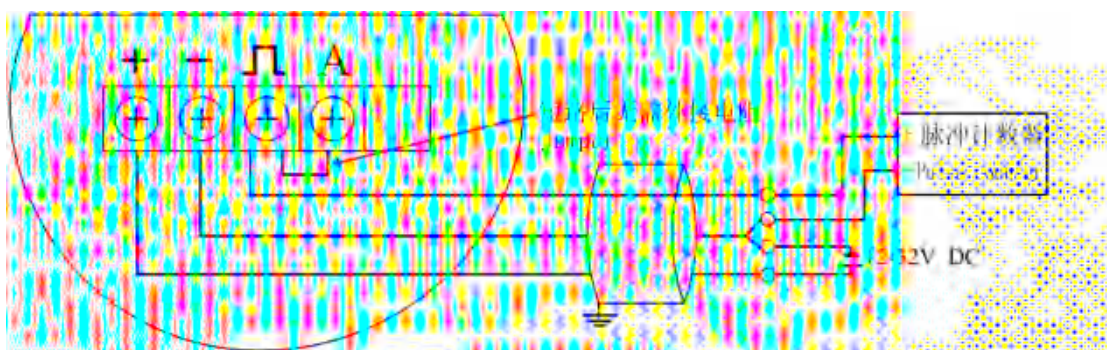
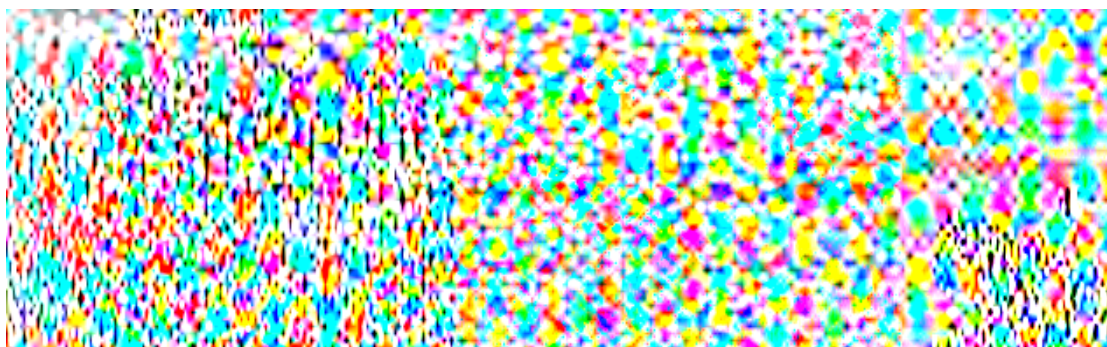



## 1

## Schedule 1 Density of Saturated Steam

(t)°C	0		1		2		3		4	
	<sup>(P)</sup> MPa	(ρ)	<sup>(P)</sup> MPa	(ρ)	<sup>(P)</sup> MPa	(ρ)	<sup>(P)</sup> MPa	(ρ)	<sup>(P)</sup> MPa	(ρ)
100	0.1013	0.5977	0.105	0.618	0.1088	0.6388	0.1127	0.6601	0.1167	0.6952
110	0.1433	0.8265	0.1481	0.8528	0.1532	0.8798	0.1583	0.9075	0.1636	0.9359
120	0.1985	1.122	0.2049	1.155	0.2114	1.19	0.2182	1.225	0.225	1.261
130	0.2701	1.497	0.2783	1.539	0.2867	1.583	0.2953	1.627	0.3041	1.672
140	0.3614	1.967	0.3718	2.019	0.3823	2.073	0.3931	2.129	0.4042	2.185
150	0.476	2.548	0.4888	2.613	0.5021	2.679	0.5155	2.747	0.5292	2.816
160	0.6181	3.26	0.6339	3.339	0.6502	3.42	0.6666	3.502	0.6835	3.586
170	0.792	4.123	0.8114	4.218	0.831	4.316	0.8511	4.415	0.8716	4.515
180	1.0027	5.16	1.0259	5.274	1.0496	5.391	1.0737	5.509	1.0983	5.629
190	1.2551	6.397	1.2829	6.532	1.3111	6.671	1.3397	6.812	1.369	6.955
200	1.5548	7.864	1.5876	8.025	1.621	8.188	1.6548	8.354	1.6892	8.522
210	1.9077	9.593	1.9462	9.782	1.9852	9.974	2.0248	10.17	2.065	10.37
220	2.3198	11.62	2.3645	11.84	2.4098	12.07	2.4559	12.3	2.5026	12.53
230	2.7975	14	2.8491	14.25	2.901	14.52	2.9546	14.78	3.0085	15.05
240	3.3477	16.76	3.407	17.06	3.467	17.37	3.5279	17.68	3.5897	17.99

	5		6		7		8		9	
(t)°C	<sup>(P)</sup> MPa	(ρ)	<sup>(P)</sup> MPa	(ρ)	<sup>(P)</sup> MPa	(ρ)	<sup>(P)</sup> MPa	(ρ)	<sup>(P)</sup> MPa	(ρ)
100	0.1208	0.7105	0.125	0.7277	0.1294	0.7515	0.1339	0.7758	0.1385	0.8008
110	0.1691	0.965	0.1746	0.9948	0.1804	1.025	0.1863	1.057	0.1923	1.089
120	0.2321	1.298	0.2393	1.336	0.2467	1.375	0.2543	1.415	0.2621	1.455
130	0.313	1.719	0.3222	1.766	0.3317	1.815	0.3414	1.864	0.3513	1.915
140	0.4155	2.242	0.4271	2.301	0.4389	2.361	0.451	2.422	0.4633	2.484
150	0.5433	2.886	0.5577	2.958	0.5723	3.032	0.5872	3.106	0.6025	3.182
160	0.7008	3.671	0.7183	3.758	0.7362	3.847	0.7544	3.937	0.773	4.029
170	0.8924	4.618	0.9137	4.723	0.9353	4.829	0.9573	4.937	0.9797	5.048
180	1.1233	5.752	1.1487	5.877	1.1746	6.003	1.201	6.312	1.2278	6.264
190	1.3987	7.1	1.4289	7.248	1.4596	7.398	1.4909	7.551	1.5225	7.706
200	1.7242	8.694	1.7597	8.868	1.7959	9.045	1.8326	9.225	1.8699	9.408
210	2.1059	10.57	2.1474	10.77	2.1896	10.98	2.2323	11.19	2.2757	11.41
220	2.55	12.76	2.5981	13	2.6469	13.24	2.6963	13.49	2.7466	13.74
230	3.0631	15.33	3.1185	15.61	3.1746	15.89	3.2316	16.18	3.2892	16.47
240	3.6522	18.31	3.7155	18.64	3.7797	18.97	3.8448	19.3	3.9107	19.64

**2**  
**Schedule 2 Density of Superheated Steam in Relationship with**  
**Temperature and Pressure Absolute**

1 Table1

P (MPa)	t (°C)								
	150	170	190	210	230	250	270	290	310
0.1	0.5164	0.4925	0.4707	0.4507	0.4323	0.4156	0.4001	0.3857	0.3724
0.15	0.7781	0.7412	0.7079	0.6777	0.65	0.6246	0.601	0.5795	0.5594
0.2	1.0423	0.9918	0.9466	0.9056	0.8684	0.8342	0.8027	0.7736	0.7465
0.25	1.3089	1.2444	1.1869	1.1349	1.0849	1.0445	1.0048	0.9682	0.9343
0.3	1.5783	1.499	1.4287	1.3653	1.3079	1.254	1.2077	1.1634	1.1224
0.4	2.1237	2.0141	1.9166	1.8297	1.7513	1.6527	1.6152	1.5554	1.5
0.5	2.6658	2.538	2.4121	2.2997	2.1992	2.1081	2.0255	1.9495	1.8802
0.8	4.3966	4.1676	3.9372	3.74	3.5655	3.411	3.2718	3.1453	3.0283
1.1	6.1313	5.8332	5.5342	5.2356	4.9719	4.7459	4.5445	4.3612	4.1943
1.4	7.8785	7.5163	7.154	6.7913	6.4288	6.1147	5.8437	5.6006	5.3794
1.7	9.8464	9.3688	9.2473	8.413	7.9352	7.5219	7.1713	6.8607	6.5815
2									

2 Table2

P (MPa)	t (°C)								
	330	350	370	390	410	430	450	470	490
0.1	0.36	0.3484	0.3375	0.3272	0.3176	0.3086	0.2998	0.2919	0.2842
0.15	0.5404	0.523	0.5066	0.4912	0.4767	0.4631	0.4502	0.4381	0.427
0.2	0.7214	0.698	0.6759	0.6553	0.636	0.6178	0.6005	0.5842	0.5688
0.25	0.9027	0.8732	0.8456	0.8198	0.7955	0.7726	0.7507	0.7316	0.7113
0.3	1.0844	1.0488	1.0156	0.9845	0.9552	0.9277	0.8989	0.8856	0.854
0.4	1.4701	1.401	1.3563	1.3144	1.2753	1.2377	1.2035	1.1708	1.1396
0.5	1.8147	1.7545	1.6983	1.6456	1.5961	1.5498	1.506	1.4648	1.4258
0.8	2.9215	2.8227	2.7305	2.644	2.5635	2.4884	2.4171	2.35	2.2869
1.1	4.0419	3.903	3.7722	3.6512	3.5384	3.4335	3.3345	3.2402	3.1529
1.4	5.1777	4.9945	4.826	4.6673	4.522	4.3857	4.2575	4.3496	4.2291
1.7	6.3309	6.0998	5.7779	5.6936	5.512	5.3441	5.1863	5.0374	4.8972
2	7.4955	7.2186	6.9619	6.726	6.5117	6.309	6.1203	5.9419	5.776
2.5	9.4806	9.1139	8.7802	8.475	8.1938	7.9332	7.6898	7.4632	7.2511
3	11.5143	11.0494	10.6308	10.2493	9.9	9.5775	9.2816	8.9991	8.7388
3.5	13.8501	13.0286	12.6162	12.0528	11.6308	11.2425	10.8842	10.5512	10.2402
4	15.749	15.0539	14.4392	13.8862	13.3077	12.9991	12.5087	12.1835	11.7548
4.5	17.9608	17.1279	16.4018	15.7527	14.7579	14.6679	14.1507	13.7009	13.2822
5	20.2508	19.2627	18.4108	17.6565	16.9827	16.3719	15.8139	15.3017	14.8249
6	25.0502	23.7006	22.557	21.5629	20.69	19.9062	19.1981	18.5495	17.9518
7	30.2231	28.4037	29.9035	25.633	24.5224	23.4021	22.6635	21.8675	21.1373
8	35.8485	33.4179	31.4825	29.8698	28.4969	27.2913	26.017	25.264	24.3864
9	42.068	38.8083	36.3217	34.3044	32.2947	31.1593	29.8733	28.4637	27.6971
10	49.2802	44.756	41.5274	39.0006	36.9344	35.1684	33.6447	32.3002	31.0863
12.5	72.0105	62.4178	56.1496	51.8212	48.5015	45.8023	43.5431	41.5884	39.8569
15	98.5531	86.5688	74.584	66.8341	61.553	57.5137	54.2497	51.5265	49.1381
17.5	126.6895	116.3142	100.8176	85.3228	76.6185	70.5711	65.9331	62.1807	59.005
20	174.3185	166.0907	137.7965	108.543	94.4945	85.3276	78.7759	73.6858	69.5196
21.5	192.3164	171.8651	150.0074	128.1614	106.636	95.1366	87.0939	81.0184	76.1621